

All-Sky Camera Calibration Techniques

2005 CEDAR Workshop

Jeff Baumgardner
Center for Space Physics
Boston University

Basic Considerations

- Take bias and dark data often
- Take darks at various exposure times
- Take off-band images for background subtraction
- When averaging data, use median not mean
- Do arithmetic in floating point...not integer
- Perform intensity calibration at least once a year...more often if camera is moved or optics are cleaned

Basic Image Processing Steps

- Subtract an appropriate dark frame from all images. If no dark frame is available with the correct exposure time, make one by using the bias exposures and interpolating to the exposure needed.
- Whenever possible, use an average of many (~ 20) darks so as not to increase noise level.

Basic Image Processing Steps (cont.)

- Make a “flat field” correction array for normalizing broad band (i.e. not related to filter spectral transmission) vignetting effects.
- Difficult because usually the light source cannot fill whole field of view and the source is not Lambertian.

Typical Imager Installation Arequipa (1994 – 2000)



Optical path of an All Sky imager built at Boston University

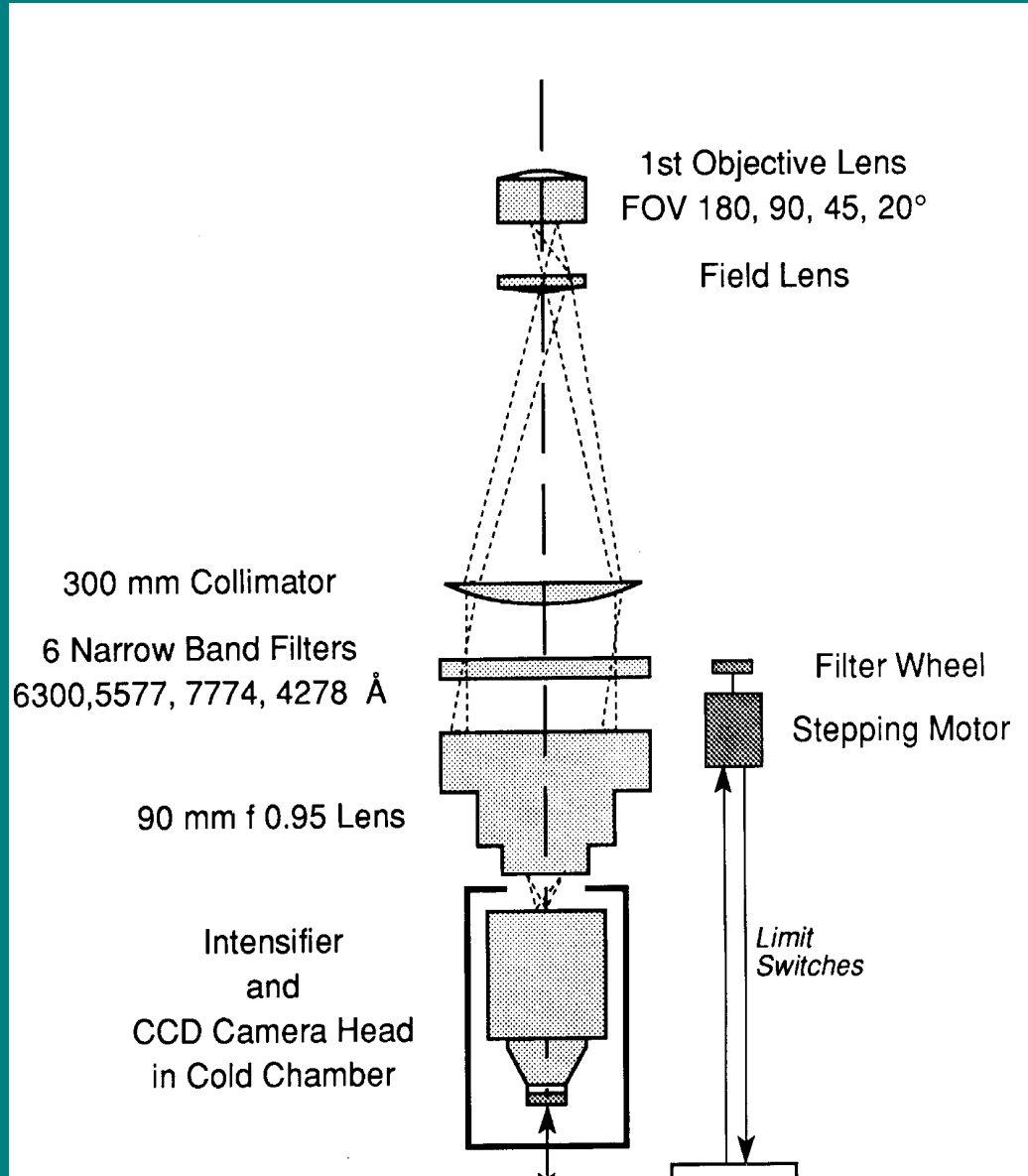

Making a vignetting correction array

- Make an intermediate flat field array by using a diffuser at the filter wheel. Here the diffuser only has to scatter light evenly over $\sim \pm 5$ deg. The diffuser is a piece of “opal glass” the same size as the filters.

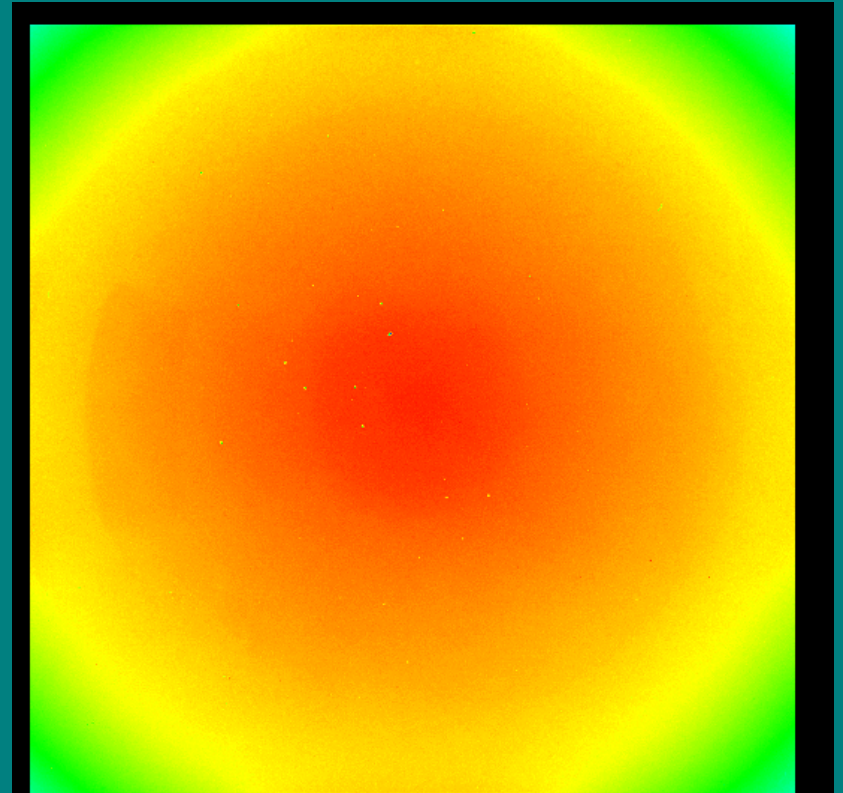

Making a vignetting correction array (cont.)

- Put a filter in place and make a series of exposures of a light box in front of all sky lens. Make sure that the whole field of view along a prime vertical is covered with plenty of overlap.



Flat field illuminator

Making a vignetting correction array (cont.)

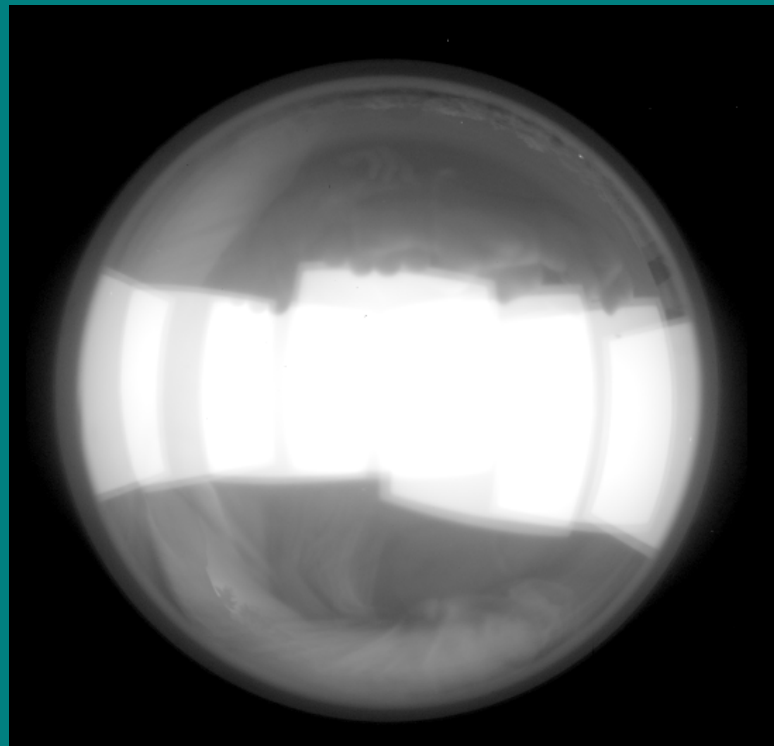

Making a vignetting correction array (cont.)

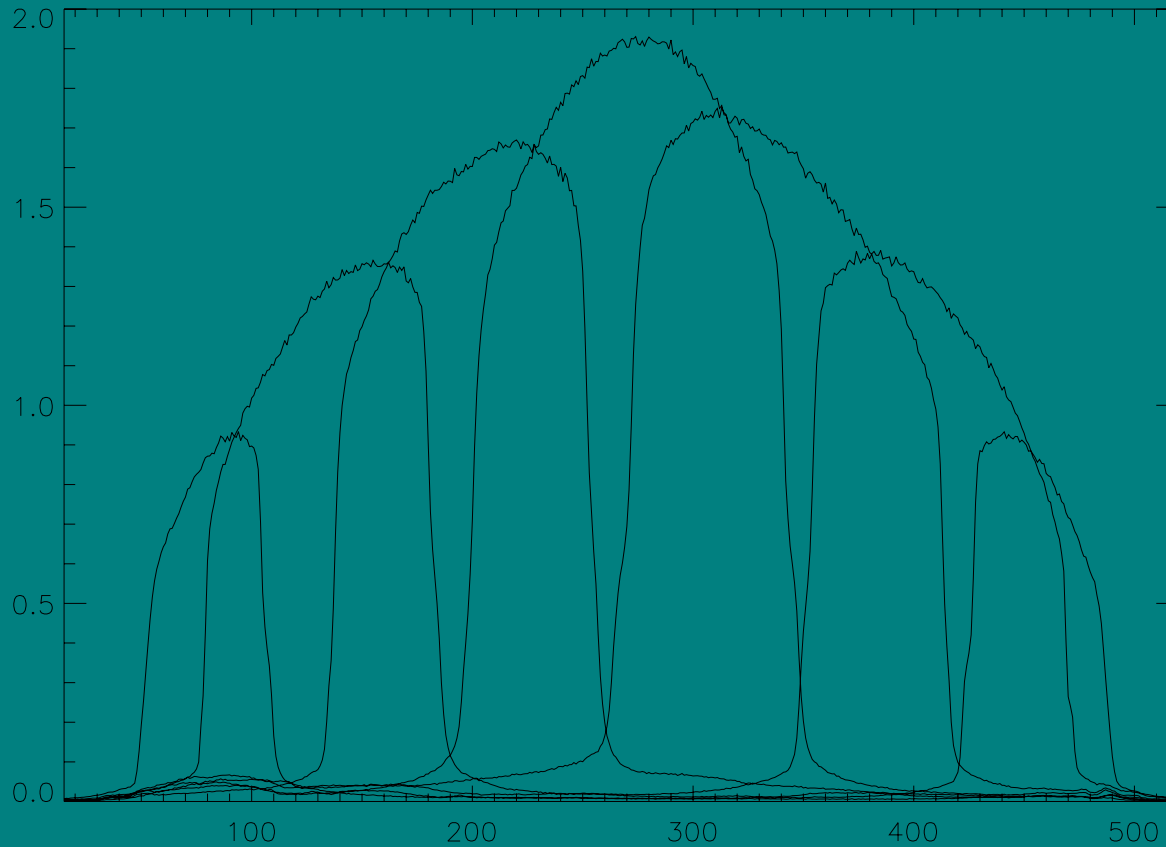

Making a vignetting correction array (cont.)

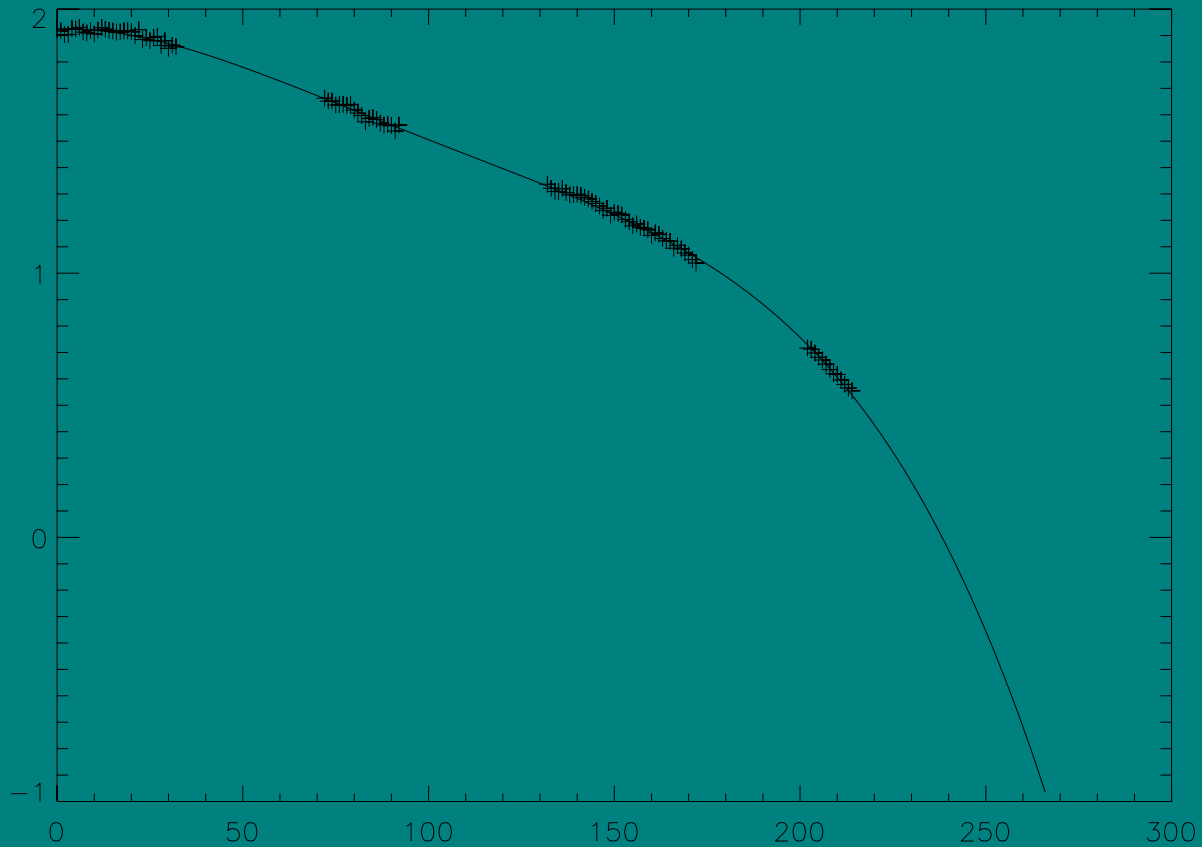

Making a vignetting correction array (cont.)

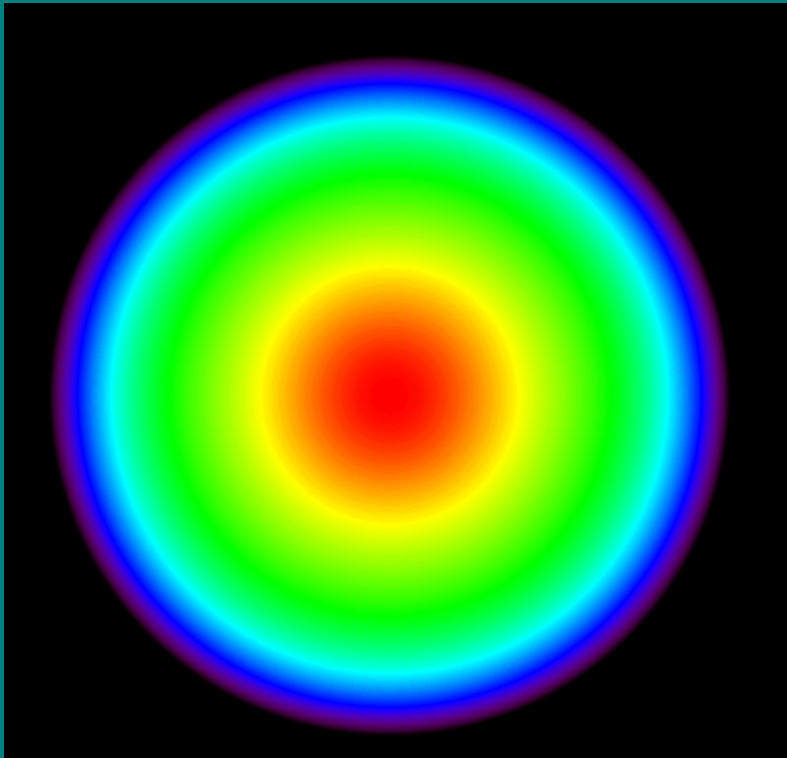

Front lens vignetting function

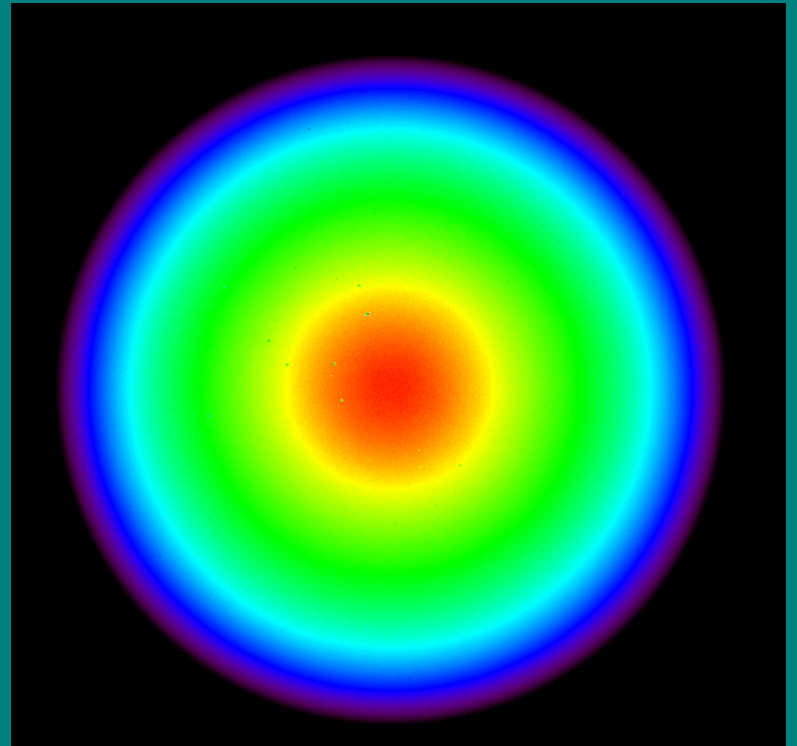

Total system vignetting function

Making a vignetting correction array (cont.)

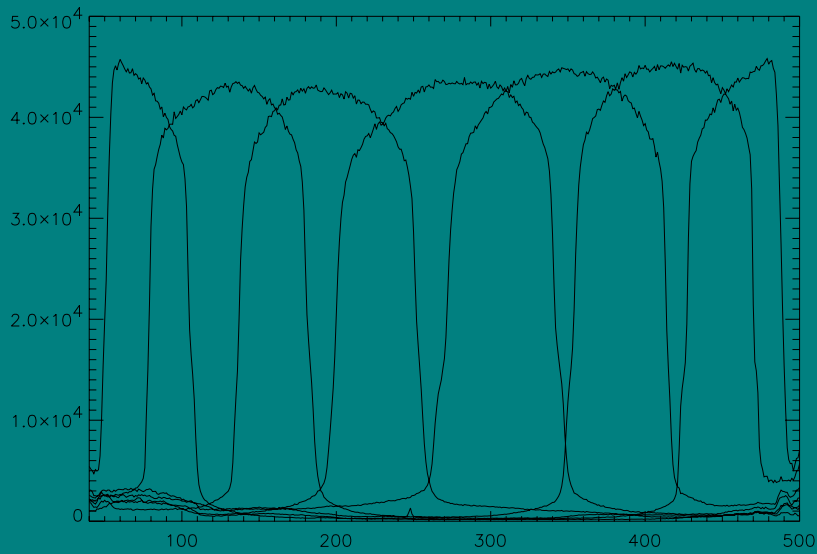

After applying vignetting function

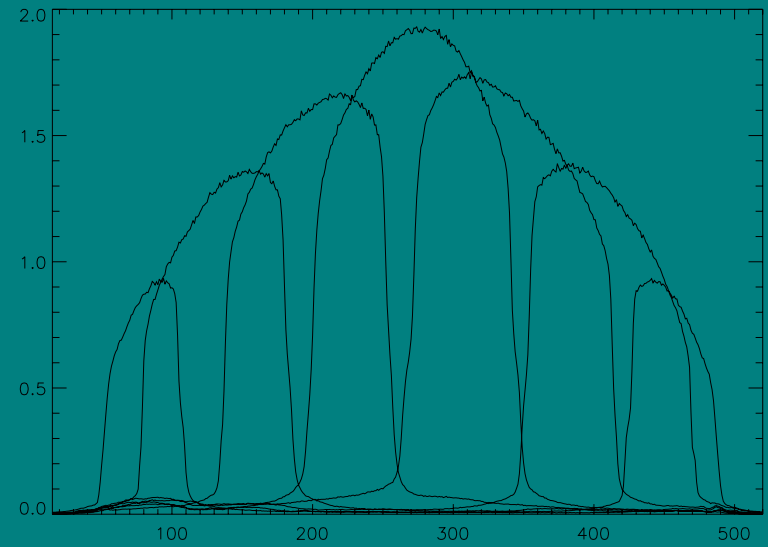

Before applying vignetting function

Intensity Calibration

- In past we have used a C14 activated source
- Very stable (some temperature sensitivity)
- Not suitable for near IR calibration
- Difficult to transport because of NRC and state regulations
- Now use tungsten lamp light box

Intensity Calibration (cont.)

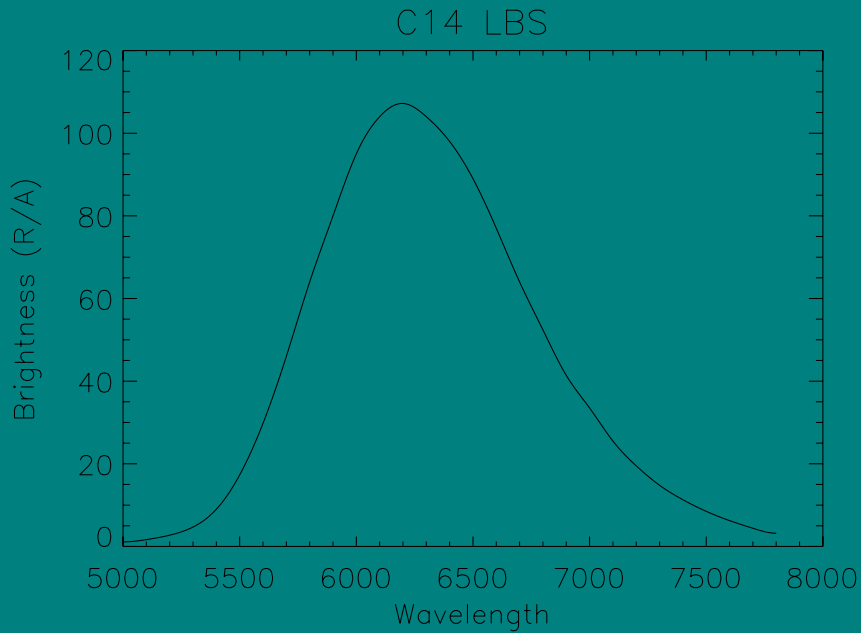

C14 light source

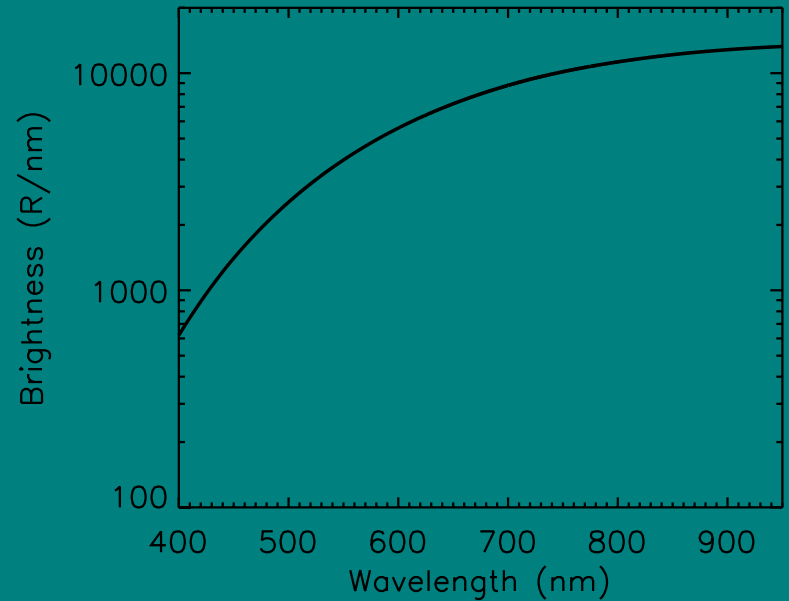

Tungsten light source

Intensity Calibration (cont.)

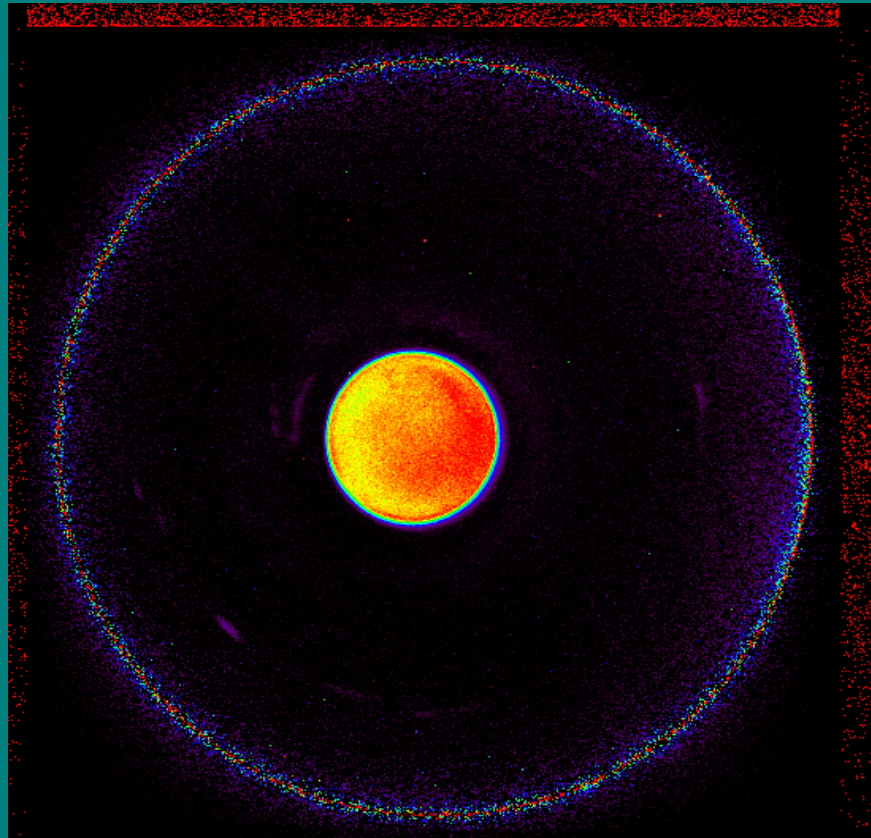

All-Sky Image of C14 Source

Intensity Calibration (cont.)

C14 Profile

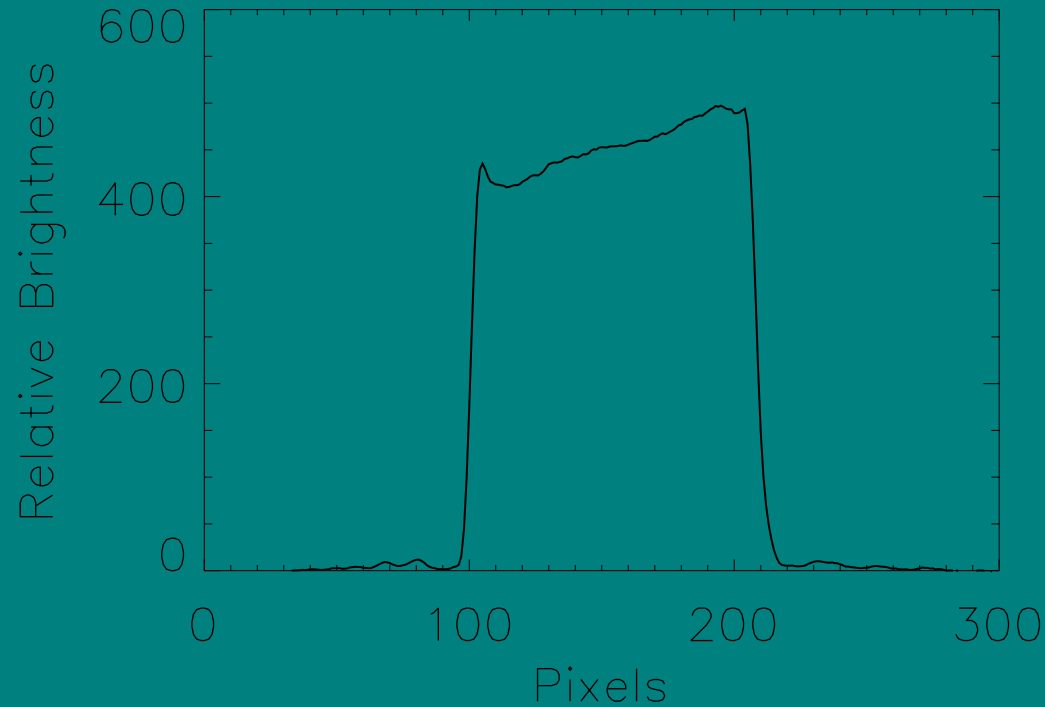

C14 source has a gradient (~20%) over surface

Intensity Calibration (cont.)

- Make a series of exposures at progressively longer integration times
- Correct each exposure for dark signal
- Flat field each exposure
- Get average of center region of light source
- Plot DN vs. exposure
($R/A * \text{Exposure Time} * \text{Filter Area}$)

Intensity Calibration (cont.)

5577 Responsivity

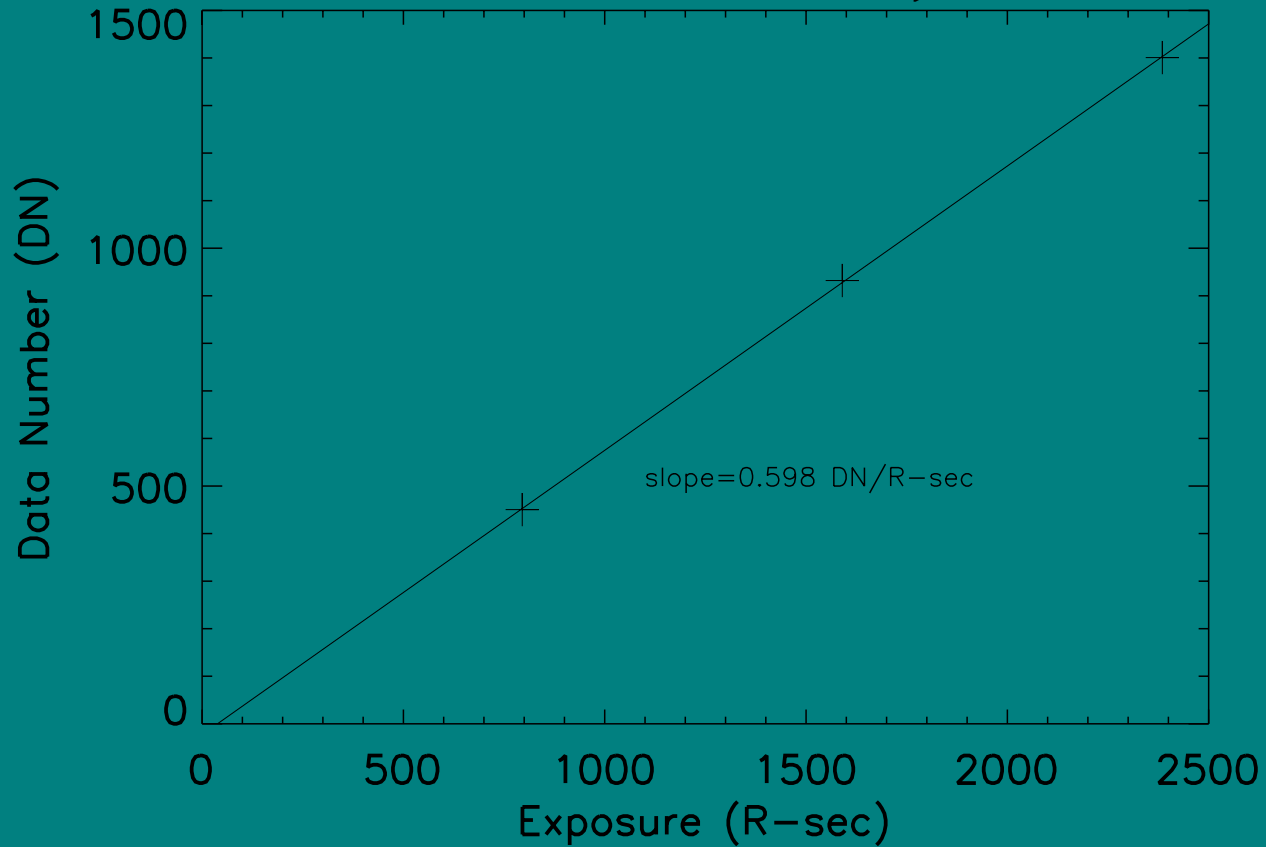

Intensity Calibration (cont.)

- Do a reality check by comparing the measured response to the predicted response.
- Area of input aperture $\sim 0.16 \text{ cm}^2$
(16mm fl @ F/3.5)
- Projected size of pixel on sky $\sim 0.16 \text{ Deg.}^2$
- $1R=24.2 \text{ photons/sec/cm}^2/\text{deg.}^2$
- Q.E. ~ 0.7 @ 5577A
- “Gain” $[\text{e}^-/\text{DN}] = 1.8$

Intensity Calibration (cont.)

1R produces: $24.2 * 0.16 * 0.16 = 0.64$
photons/sec/pixel

or $0.64 * 0.7 = 0.45$ e-/sec/pixel

or $0.45/1.8 = 0.25$ DN/sec or 4 R-sec/DN
(assuming 100% system efficiency!)

This is less than the measured responsivity by a factor of almost three! Something must be wrong with the measured value.

Intensity Calibration (cont.)

- Upon review of the program that produced the responsivity curve, I discovered that the filter area (7.2A) was left out. The responsivity should be less by this factor or $0.598/7.2 = 0.083$ DN/R-sec. or ~ 12 R-sec/DN. This is less sensitive than the above calculation which would be expected, since the “back of the envelope” calculation assumed 100% system efficiency.

Intensity Calibration (cont.)

- The previous responsivity calculation would be the whole story if the interference filter used had a transmission of 100% everywhere in the field of view.
- Typical filters have transmissions of ~70%, so measured values must be increased by a factor of $1/0.7$ or 1.43...but this factor varies over the field of view for collimating systems.

Interference Filter Characterization

5577m

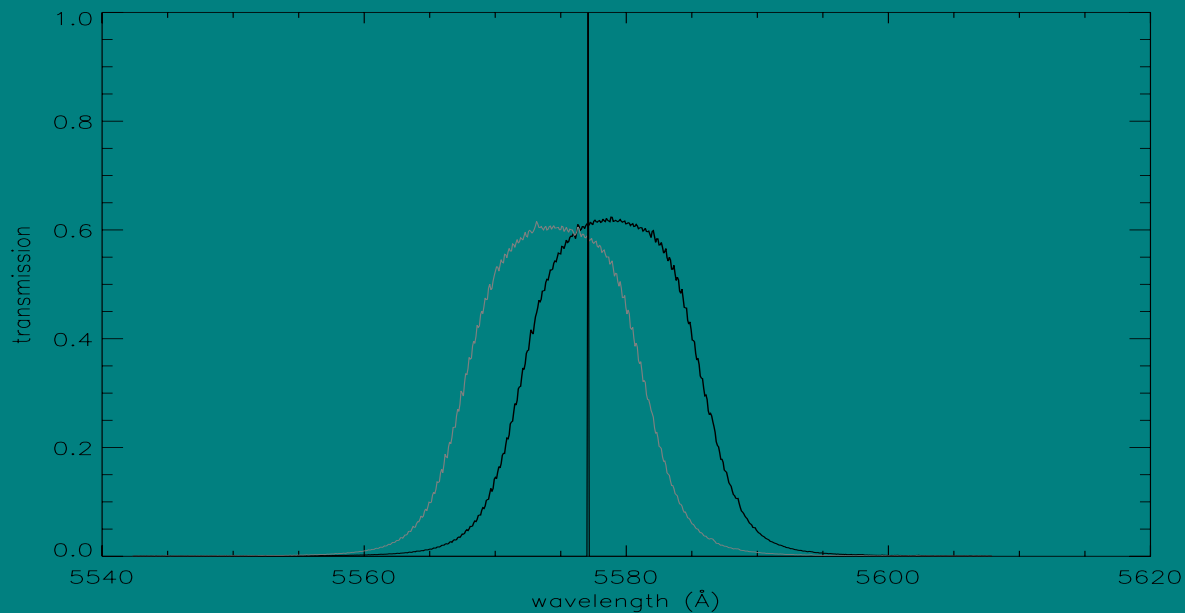

8/06/04

Area=8.97265(Å)

Dispersion=0.0871985(Å/pix)

Temperature=25°C

Angle of incidence =0°, thick line

Angle of incidence =5°, thin line

Interference Filter Characterization (cont.)

- Make a 2d representation of filter shift with angle of incidence.

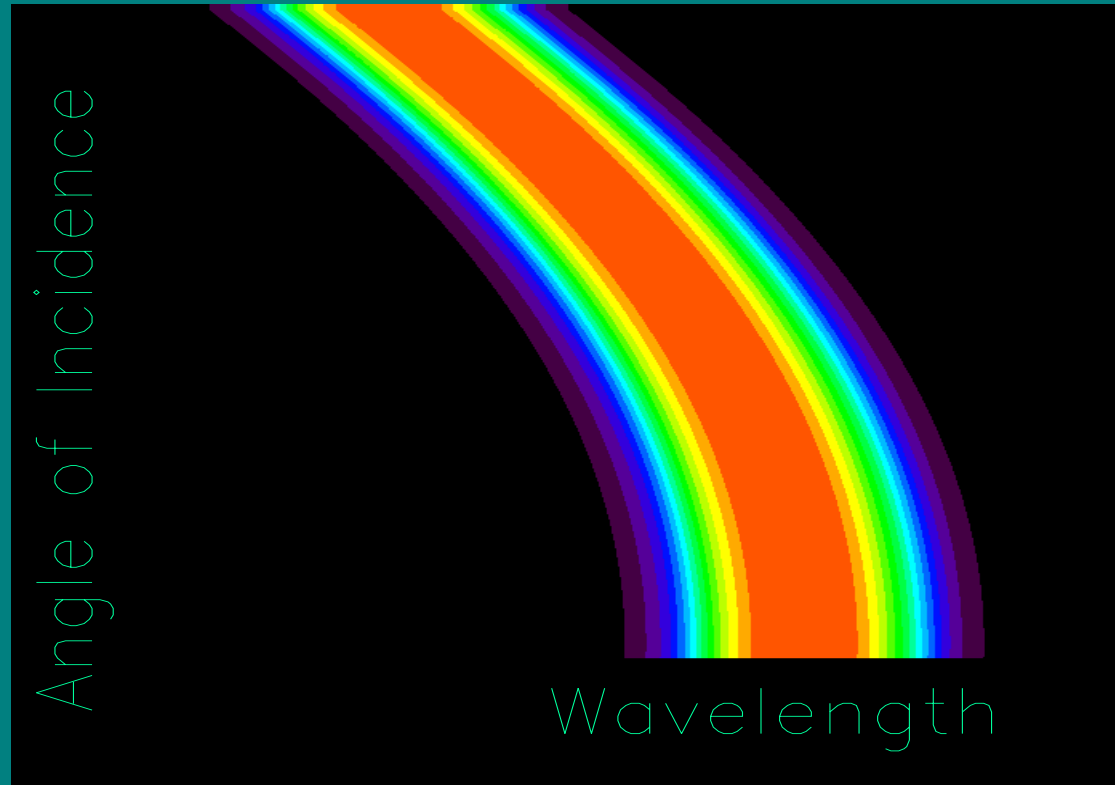

Interference Filter Characterization (cont.)

- A horizontal cut through this image is a standard filter transmission curve at a given angle of incidence.
- A vertical cut through this image is the transmission of the filter at a specific wavelength as a function of incident angle.
- Use the vertical cut profile to make a radially symmetric function as was done earlier with the vignetting array.

Interference Filter Characterization (cont.)

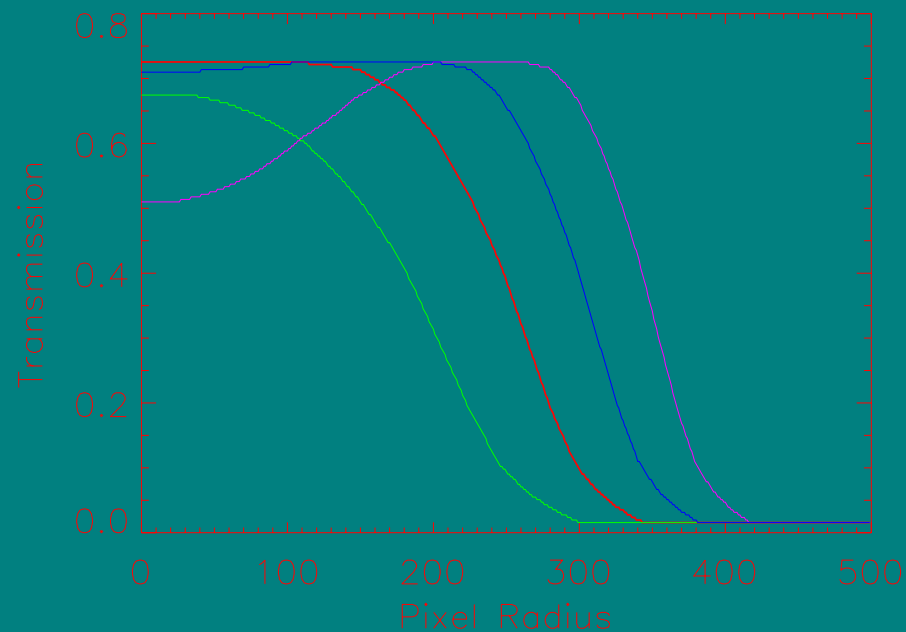
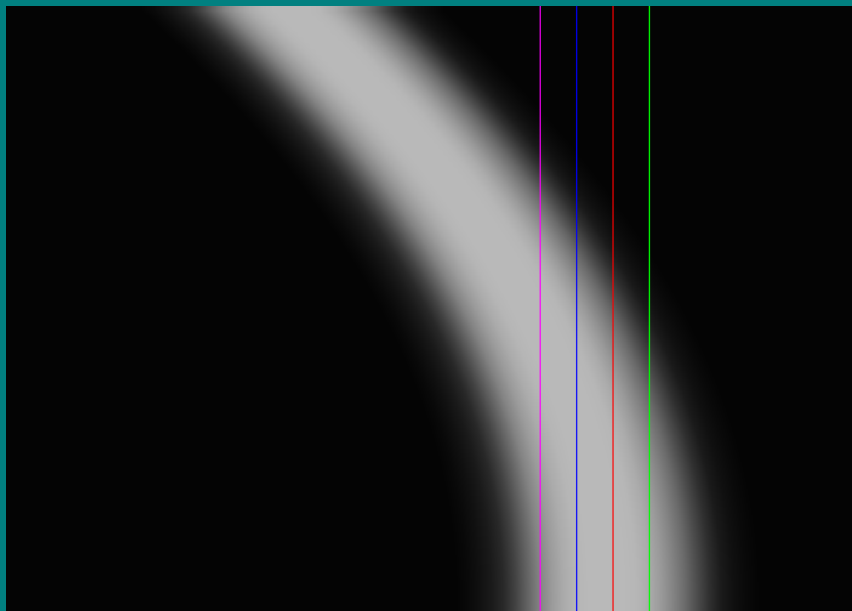

Summary of steps

- Subtract dark from all images
- Normalize images using broad-band vignetting function
- Use appropriate responsivity factors to get Rayleighs
- Subtract off-band image (it may have to be scaled to account for different continuum brightness and filter areas)
- Correct final image with filter transmission array

Conclusion

- Importance of filter characterization
- Telecentric systems will need different procedures to account for filter transmission non-uniformities
- The problem of “fringing” or “etaloning” in near IR monochromatic imagers needs to be addressed
- The effects of the troposphere need to be addressed